

MOORING WINCH

MOORING WINCH – SINGLE DRUM (HYDRAULIC DRIVE)

Product Code: WDH - A

| Model | Hawser Drum (At 1st Layer) | | | | | | Hydraulic Motor | |
|-----------|----------------------------|--------------|---------------|------------------|-------------|-----------|-----------------|----------------|
| | Pull Load | Holding Load | Nominal Speed | Light-Line Speed | Hawser Dia. | Drum Dia. | Type | Required Power |
| | (kN) | (kN) | (M/min) | (M/min) | (mm) | (mm) | | (kW) |
| WDH-A-050 | 50 | 150 | 15 | 30 | 55 | 400 | GM1 | 22 |
| WDH-A-100 | 100 | 260 | 15 | 30 | 65 | 400 | GM2 | 50 |
| WDH-A-125 | 125 | 350 | 15 | 30 | 70 | 450 | GM2 | 62 |
| WDH-A-160 | 160 | 470 | 15 | 30 | 70 | 450 | GM2 | 75 |
| WDH-A-200 | 200 | 590 | 15 | 30 | 76 | 450 | GM3 | 94 |
| WDH-A-250 | 250 | 730 | 15 | 30 | 80 | 450 | GM4 | 110 |

* Hawser Storage : 220M

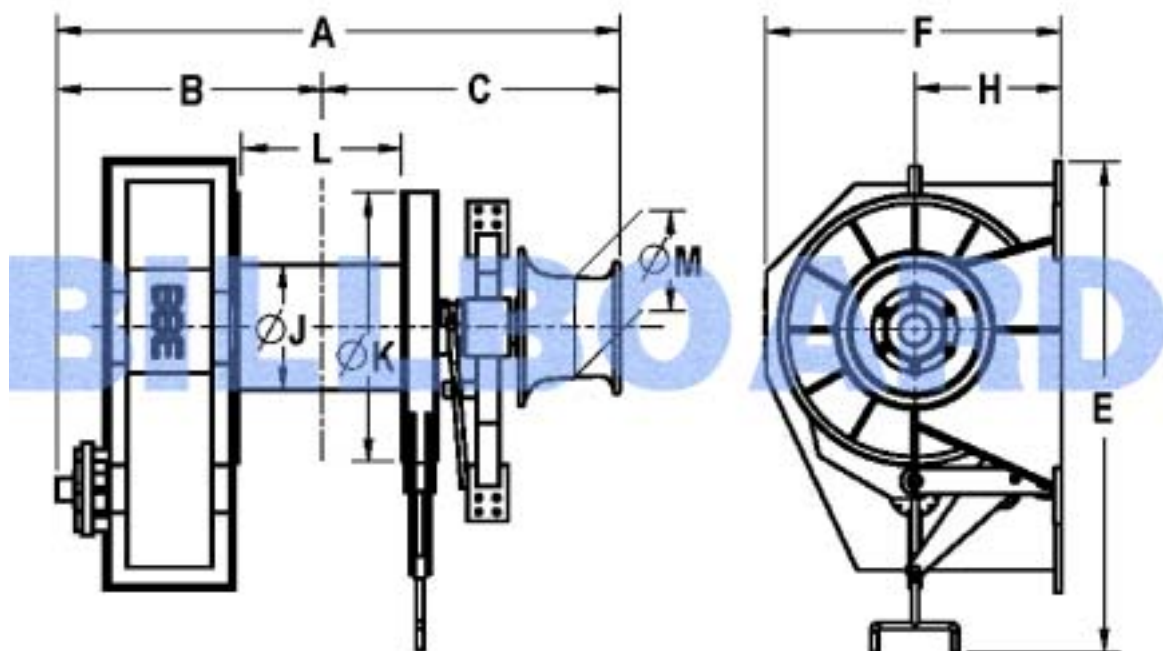

| Model | Outside Dimensions (mm) | | | | | | | | | |
|-----------|-------------------------|------|------|------|------|-----|-----|------|-----|-----|
| | A | B | C | E | F | H | J | K | L | M |
| WDH-A-050 | 2600 | 1400 | 980 | 1560 | 1420 | 620 | 400 | 1200 | 800 | 400 |
| WDH-A-100 | 2650 | 1550 | 1100 | 1800 | 1600 | 750 | 400 | 1360 | 880 | 400 |
| WDH-A-125 | 2785 | 1650 | 1135 | 1850 | 1600 | 760 | 450 | 1560 | 880 | 400 |
| WDH-A-160 | 3010 | 1800 | 1210 | 1900 | 1700 | 760 | 450 | 1560 | 880 | 450 |
| WDH-A-200 | 3155 | 1900 | 1255 | 2200 | 1800 | 800 | 450 | 1660 | 920 | 450 |
| WDH-A-250 | 3285 | 2000 | 1285 | 2300 | 1950 | 900 | 450 | 1730 | 920 | 450 |

Remark:

1. Compact design minimize space required for installation.
2. Simple design along with integrated and sealed for easy of inspection and maintenance.
3. Total enclosed gear type and local control.
4. Hydraulic Brake, Clutch as request.
5. Remote Control or Auto-Tension are available as request.
6. Electric Driven with frequency inverter as request.