

FAIRLEADS – UNIVERSAL ROLLERS

HORIZONTAL FAIRLEAD ROLLER – JIS F-2026 TYPE A (4 ROLLERS)

Product Code: AF-2026-A

(JIS F-2026-A)

Nominal Dia. (mm)	Dimensions (mm)								Open Size	Wire Rope Dia.	SWL (Ton)	Mass (kgs)
	B	D1	D2	D3	H	H1	L	L1				
140	355	140	140	114	542	275	805	335	148 X 195	18	12	214
160	405	165	165	114	584	290	890	365	149 X 197	22.4	17	307
180	455	190	190	140	636	315	960	390	148 X 196	25	24	411
200	505	216	216	140	680	330	1049	420	150 X 226	28	28	568
250	610	267	267	165	824	415	1303	520	194 X 247	35	46	1000
315	715	318	318	216	998	420	1562	620	260 X 295	42	60	1624

JIS F-2026 Type A – 4 Rollers

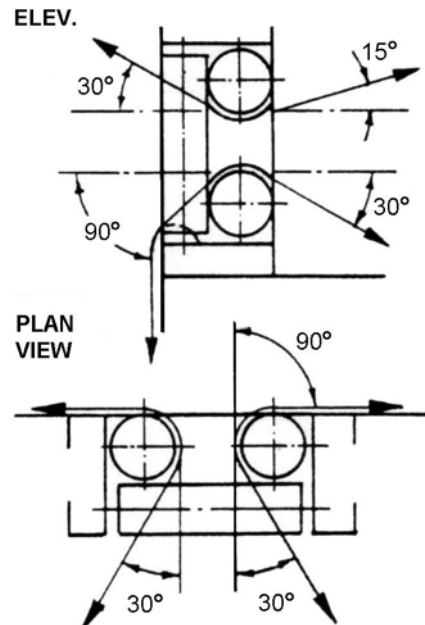
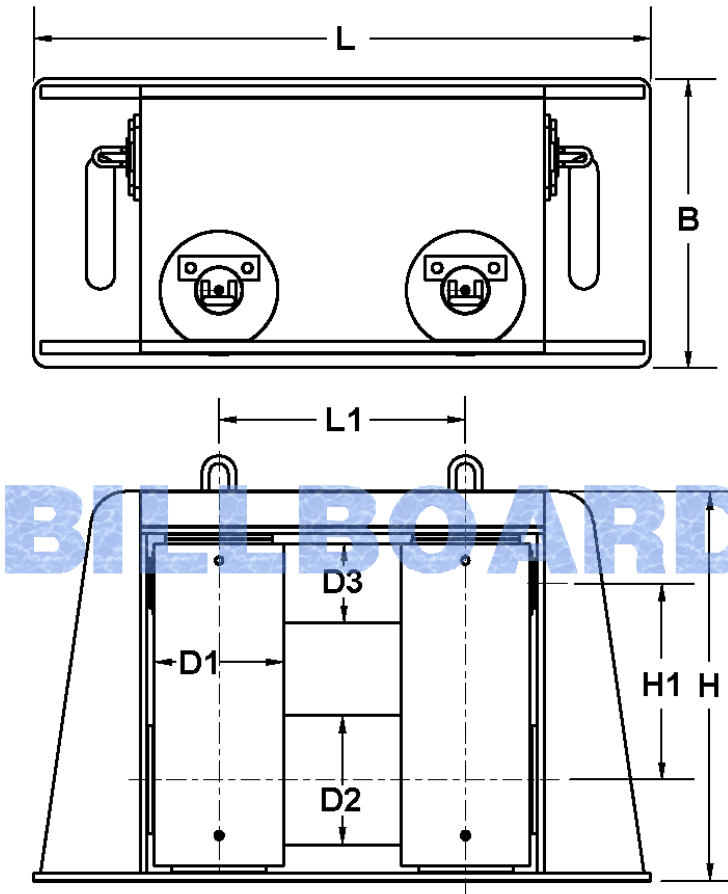

Note:

1. MBL may be MBL of actual Mooring Line.
2. Inboard Line Leads may correspond to actual Leads to Winch Drum.
3. Position of Line in aperture to be assumed such as to produce max. stress in part investigated.
4. Assume highest position to calculate stress in frame and roller bearings; at mid-length of Roller to calculate bending in Roller.